

NATURAL GAS ENGINE

**KUBOTA DG SERIES (3-cylinder)**

# DG972-E2



## RATED POWER

**17.6kW@3600rpm**



Photograph may show non-standard equipment.

## PERFORMANCE CURVE

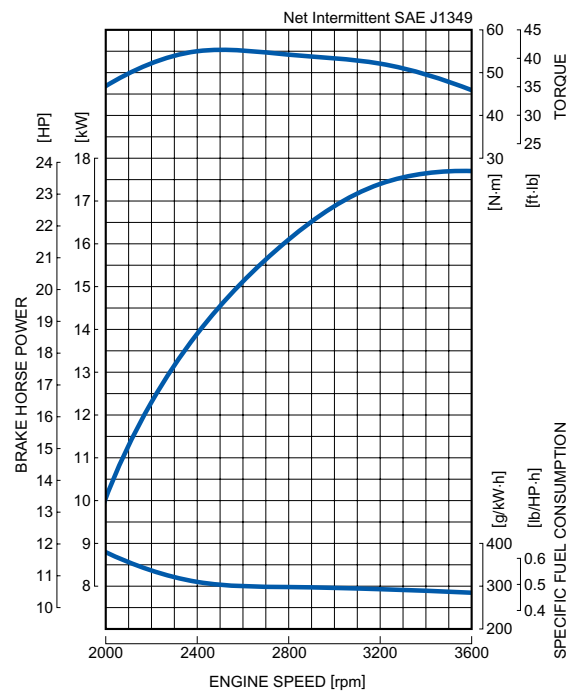

## FEATURES and BENEFITS

### New Engine Series

- The Kubota DG Series offers a new solution to the increasing needs for natural gas engine. The diesel engine based Kubota DG Series gives users the same foot-print, reliability and durability of D902, WG972, and DF972 acknowledged as the world's top quality small industrial engines.
- Kubota offers SAE Flywheel Housing and Rear End Plate specifications for the DG972 engine. These options offer users flexible Power Take Off (PTO) choices.
- The Kubota DG Series is designed to endure use outdoors under severe environment. This series is equipped with a bypass breather tube to avoid freezing below zero.

### Emission

- Kubota DG Series complies with EPA Tier 2 Emissions Regulations. EPA regulation is one of the most stringent emissions regulations in the world.

### Best Fuel System

- Specialized for Natural Gas use, the DG972 engine eliminated the carburetor, regulator and a fuel filter parts, which are only necessary for Gasoline or LPG use. Also, Kubota adopts the best jet set and the ignition timing that provides the best engine performance in severe conditions.

### Ease maintenance cost and time

- Mechanical governor system will contribute to lower maintenance cost and prevents users from having to deal with complicated electric maintenance. Moreover, water resistant spark plug caps are adopted for outdoor use.

## GENERAL SPECIFICATION

|                             |           |   |
|-----------------------------|-----------|---|
| Model                       |           | <b>DG972-E2</b>   |
| Emission Regulation         |           | Tier 2  |
| Type                        |           | Vertical 4-cycle Liquid Cooled Natural Gas                |
| Number of Cylinders         |           | 3   |
| Bore                        | mm (in)   | 74.5 (2.93)   |
| Stroke                      | mm (in)   | 73.6 (2.9)  |
| Displacement                | L (cu.in) | 0.962 (58.70)   |
| Fuel                        |           | Natural Gas   |
| Intake System               |           | Naturally Aspirated                                       |
| Maximum Speed               | rpm       | 3600  |
| Output:<br>Net Intermittent | kW        | 17.6  |
|                             | hp        | 23.6  |
|                             | ps        | 23.9  |
| Direction of Rotation       |           | Counterclockwise Viewed on Flywheel                       |
| Oil Pan Capacity            | L (gal)   | 3.7 (0.98)  |
| Starter Capacity            | V-kW      | 12-1.0  |
| Alternator Capacity         | V-A       | 12-40   |
| Length                      | mm (in)   | 525.5 (20.69)* <sup>1</sup> / 452.5 (17.81)* <sup>2</sup> |
| Width                       | mm (in)   | 415.4 (16.35)   |
| Height (1)                  | mm (in)   | 502.5 (19.78)   |
| Height (2)                  | mm (in)   | 159.0 (6.26)  |
| Dry Weight                  | kg (lb)   | 72.0 (158.7)* <sup>1</sup> / 95.4 (210.3)* <sup>2</sup>   |

\*Specification is subject to change without notice.

\*Output: Net Intermittent SAE J1349

\*Dry weight is according to Kubota's standard specification.  
When specification varies, the weight will vary accordingly.

\*<sup>1</sup> with SAE Flywheel and Housing

\*<sup>2</sup> with Rear End Plate

## DIMENSIONS

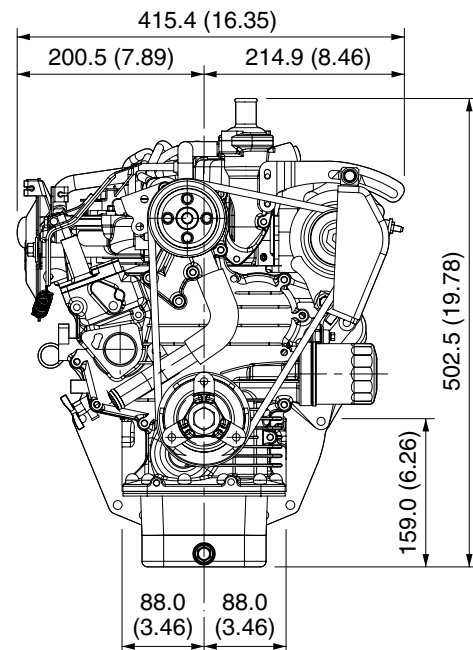
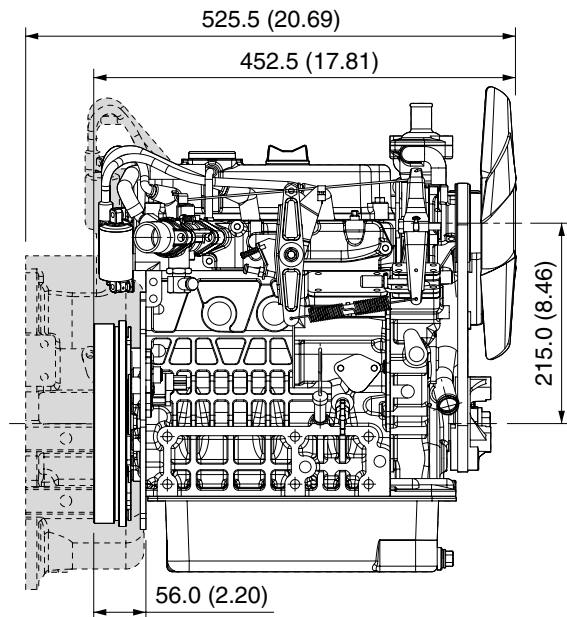

## KUBOTA Corporation

2-47, Shikitsuhigashi 1-chome, Naniwa-ku, Osaka, 556-8601 Japan  
Fax: 06-6648-3521

<http://www.engine.kubota.co.jp>

Your Driving Force  
KUBOTA ENGINE