



an EnPro Industries company

QRNG[®] Series

Instruction Manual

This manual contains important safety information and must be carefully read in its entirety and understood prior to installation by all personnel who install, operate and/or maintain this product.

Manual No. 50158-101

July 2003 Edition

WARRANTY

Quincy Compressor
Industrial Reciprocating Products
QRNG Natural Gas Series Compressors

GENERAL PROVISIONS

Quincy Compressor (The Seller) warrants to each retail purchaser (Purchaser) products of the Seller's own manufacture against defects in material and workmanship. With respect to products not manufactured by the Seller, the Seller will, if practical, pass along the warranty of the original manufacturer.

The Seller's sole obligation under this warranty shall be, at its option, to repair, replace, or refund the purchase price of any product or part thereof which is deemed to be defective, provided the Purchaser meets all of the applicable requirements of this warranty and none of the limitations apply.

WARRANTY PERIODS

QRNG Pressure Lubricated Basic Compressors

Seller warrants for six (6) months from date of factory shipment or three (3) months from date of installation, whichever comes first, the following parts: head, cylinder, crankcase, lubricant pump, crankshaft, pistons, connecting rod assemblies and bearings. Material and workmanship only. No reimbursement for travel to be allowed.

Replacement Parts

Seller warrants repaired or replaced parts of its own manufacture against defects in material and workmanship under normal use and service for ninety (90) days, or for the remainder of the warranty on the product being repaired, whichever is longer.

Parts purchased outside the compressor's warranty period are warranted for ninety (90) days from the date of distributor sale, or one (1) year from the date of shipment from the factory, whichever occurs first.

Normal maintenance items and procedures are not warranted unless found to be defective in material or workmanship, i.e. but not limited to filters, gaskets, rings, valves and control lines.

Limitations

Notice of the alleged defect must be given to the Seller in writing with all identifying details, including serial number, model number, type of equipment and date of purchase within thirty (30) days of discovery of same during the warranty period. If requested by Seller, such product or product thereof must be promptly returned to Seller, freight prepaid for inspection.

The Seller must have the warranty registration card on file at Quincy, IL. within ten (10) days of start-up or the warranty may be declared null and void.

The above warranties shall not apply and Seller shall not be responsible nor liable for:

- (a) Consequential, collateral or special losses or damages.
- (b) Equipment conditions caused by fair wear and tear, abnormal conditions, accident, neglect or misuse of equipment, improper storage or damages resulting during shipment.
- (c) Deviation from operating instructions, specifications or other terms of sales.
- (d) Labor charges, loss or damage resulting from improper operation, maintenance or repairs made by person(s) other than Seller or Seller's authorized service station.
- (e) Improper application or installation of product.
- (f) Compression of other than sweet, dry natural gas as defined by NACE MRO 175.
- (g) Inadequate filtration (scrubbing) of inlet natural gas.
- (h) Failure to maintain adequate lubricant in the crankcase.

Disclaimer

In no event shall Seller be liable for any claims, whether arising from breach of contract or warranty or claims of negligence or negligent manufacture, in excess of the purchase price.

This warranty is the sole warranty of Seller and any other warranties, express, implied in law or implied in fact, including any warranties of merchantability and fitness for particular use, are hereby specifically excluded.

Contents

SECTION 1	SAFETY
Safety First	1
Summary of Changes	3
SECTION 2	SYSTEM DYNAMICS
Description & Application	4
Principles of Compression Cycles	4
Principles of Lubrication Systems	4
Specifications	5
SECTION 3	INSTALLATION
Receiving Delivery	6
Freight Damage	6
Location	7
Electrical Supply Requirements	8
Mounting	8
System Components	9
Induction System	10
Compressed Natural Gas Discharge System	10
SECTION 4	START-UP & OPERATION
Pre-Starting Checklist	11
Initial Starting & Operating	12
Daily Starting Checklist	12
SECTION 5	MAINTENANCE & LUBRICATION
Stopping for Maintenance	13
Maintenance Schedule	13
Maintenance Schedule Checklist Sample	14
Lubrication	14
Pulley / Sheave Alignment & Belt Tension	15
Reversal of Compressor Rotation	15
Torquing Cylinder to Head Capscrews	17
SECTION 6	TROUBLESHOOTING
Troubleshooting	18

Safety First

At Quincy Compressor safety is not only a primary concern, but a faithfully performed practice. Beginning with the design stage, safety is built into “The World’s Finest Compressor”. It is the intention of this manual to pass along the “safety first” concept to you by providing safety precautions throughout its pages.

“**DANGER!**”, “**WARNING!**”, and “**CAUTION!**” are displayed in large bold capital letters in the left hand column to call attention to areas of vital concern. They represent different degrees of hazard seriousness, as stated below. The safety precaution is spelled out in bold upper and lower case letters in the right hand column.

DANGER !

Immediate hazards which will result in severe personal injury or death.

WARNING !

Hazards or unsafe practices that could result in personal injury or death.

CAUTION !

Hazards or unsafe practices which could result in minor personal injury, product or property damage.

Each section of this instruction manual, as well as any instructions supplied by manufacturers of supporting equipment, should be read and understood prior to starting the compressor. If there are any questions regarding any part of the instructions, please call your local Quincy Compressor distributor, or the Quincy Compressor factory before creating a potentially hazardous situation. Life, limb, or equipment could be saved with a simple phone call.

Compressors are precision high speed mechanical equipment requiring caution in operation to minimize hazard to property and personnel. There are many obvious safety rules that must be observed in the operation of this type of equipment. Listed below are some additional safety precautions that must be observed.

- Transfer of toxic, dangerous, flammable or explosive substances using Quincy Compressor products is at the user’s risk.
- Turn off and lockout/tagout (per OSHA regulation 1910.147) the main power disconnect switch before attempting to work or perform any maintenance.
- Do not attempt to service any part of the unit while it is operating.
- Per OSHA regulation 1910.147, relieve the system of all pressure before attempting to service any part of the unit.
- Do not operate the unit with any of its safety guards, shields, or screens removed.

- Allow ample time for the compressor to cool before performing service procedures. Some surface temperatures exceed 350°F when the compressor is operating.
- Do not remove or paint over any DANGER!, WARNING!, CAUTION!, or instructional materials attached to the compressor. Lack of information regarding hazardous conditions can cause property damage or personal injury.
- Periodically check all pressure relief valves for proper operation.
- Do not change the pressure setting of the pressure relief valve, restrict the function of the pressure relief valve, or replace the pressure relief valve with a plug.
- Do not install a shutoff valve in the compressor discharge line without first installing a pressure relief valve of proper size and design between the shutoff valve and the compressor.
- Do not use plastic pipe, rubber hose, or lead-tin soldered joints in any part of the compressed gas system.
- Alterations must not be made to this compressor without Quincy Compressor's approval.
- Be sure that all tools, shipping and installation debris have been removed from the compressor and installation site prior to starting the compressor.
- Do not operate the compressor in excess of the ASME pressure vessel rating for the receiver or the service rating of the compressor, whichever is lower.
- Make a general overall inspection of the unit daily and correct any unsafe situations. All fasteners and fittings must be kept tight.
- Reckless behaviour of any kind involving compressed gas is dangerous and can cause very serious injury to the participants.
- Provisions should be made to have the instruction manual readily available to the operator and maintenance personnel. If for any reason any part of the manual becomes illegible or the manual is lost, have it replaced immediately. The instruction manual should be read periodically to refresh one's memory. It may prevent a serious or fatal accident.
- Never use a flammable or toxic solvent for cleaning the inlet filter or any parts.

DANGER !

Air used for breathing or food processing must meet OSHA. 29 CFR 1910.134 or FDA 21 CFR 178.3570 regulations. Failure to do so may cause severe injury or death.

WARNING !

Do not operate a Quincy natural gas compressor in excess of its published rating listed in the parts book.

The owner, lessor or operator of any compressor unit manufactured by Quincy Compressor is hereby warned that failure to observe the safety precautions and procedures outlined in this manual may result in serious personal injury, damage to property, and may void your warranty. Quincy Compressor must authorize all warranty service. Before contacting your distributor or the factory, check the maintenance requirements and the troubleshooting guide for your compressor. Most warranty issues can be resolved by following proper maintenance procedures.

Quincy Compressor neither states as fact, nor in any way implies that the above list of safety precautions is an all inclusive list, the observance of which will prevent all damage to property or injury to personnel.

Quincy Compressor's liability is limited to the basic compressor as supplied by Quincy Compressor, and is limited in defects in material and workmanship. Any modifications of system components related to the operation of the basic compressor such as (but not limited to) the suction and discharge connections and drive arrangements are the responsibility of the owner / operator.

Every effort has been taken to ensure that complete and correct instructions have been included in this manual. However, possible product updates and changes may have occurred since this printing. Quincy Compressor reserves the right to change specifications without incurring any obligation for equipment previously or subsequently sold.

***Summary of Significant Changes to This Manual
(since previous printing dated August 1997):***

- Added Terms & Conditions statement
- Edited verbiage pertaining to lubrication (compressors shipped with lubrication in the crankcase).
- Removed torque specifications (torque specifications are now available in respective parts books).

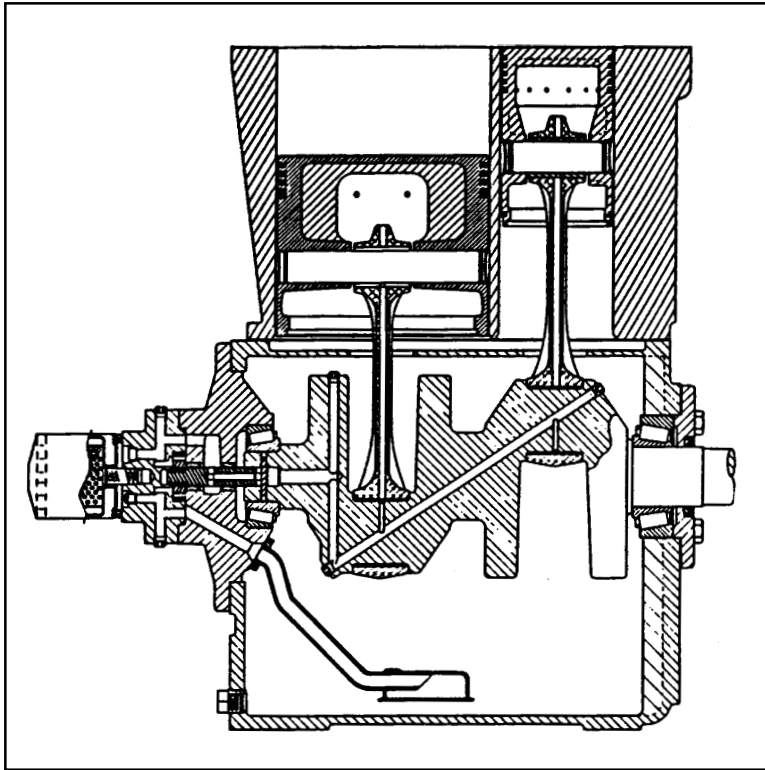

**Fig. 2-1 Cross Section of Typical QRNG
2 Stage Pressure Lubricated Cylinder & Crankcase**

PIX1064

Description & Application

Quincy Compressor QRNG Series natural gas compressors are heavy duty industrial, aircooled, single acting, belt driven, single or two stage compressors. These compressors are designed to compress sweet gas only (with a hydrogen sulfide content no greater than 10 ppm).

Principles of Compression Cycles

Single Stage Compressors

During the downstroke of a single stage natural gas compressor, natural gas is drawn through an intake valve in the head of the compressor and into the compression cylinder. At the bottom of the stroke, the intake valve closes and natural gas is trapped in the cylinder. The natural gas is then compressed in the cylinder during the upstroke of the piston. Total compression, from intake pressure to the final discharge pressure, is accomplished in one stroke of the piston.

Two Stage Compressors

During the downstroke of a two stage natural gas compressor, natural gas is drawn through an intake valve in the head of the compressor into the low pressure cylinder and compressed during the upstroke of the piston.

The compressed natural gas is then released through a discharge valve in the head of the compressor to an intercooler (usually finned tubing) where the heat resulting from compression is allowed to dissipate. The cooler, compressed natural gas is then drawn into a second compression cylinder, the high pressure cylinder, for compression to final pressure.

From there the compressed natural gas is released through a discharge valve to a natural gas receiver tank or directly to a network of compressed natural gas supply lines. In one revolution of the crankshaft a compression cycle is completed.

Principles of Lubrication Systems

Moving parts within the crankcase are supplied with lubrication by a positive displacement, gerotor type lubricant pump. Lubricant is drawn up from the bottom of the crankcase to the lubricant pump through an lubricant sump strainer screen. The lubricant is then forced under pressure through the lubricant filter (if so equipped). Lubricant travels under pressure through drilled journals in the crankshaft and connecting rods to lubricate crankshaft bearings, wrist pin bearings and the cylinder walls.

Specifications

Single Stage Models

	QRNG 240	QRNG 270	QRNG 4125
Cylinder Bore Dia.	4.001 / 4.000	4.501 / 4.500	4.501 / 4.500
Piston Skirt Dia.	3.9985 / 3.9980	4.491 / 4.490	4.491 / 4.490
Piston / Cylinder (at skirt)	.0015 / .003	.009 / .011	.009 / .011
Crankshaft Dia. (at main bearing)	1.5015 / 1.5025	2.0015 / 2.0025	2.1265 / 2.1275
Housing Bore (at main bearing)	3.000 / 3.001	3.6718 / 3.6728	4.375 / 4.376
Crankshaft End Play	.0015 / .003	.0015 / .003	.002 / .0035
Crankshaft Journal Size	1.7500 / 1.7505	2.2480 / 2.2485	2.2480 / 2.2485

Two Stage Models

		QRNG 325	QRNG 340	QRNG 350
Cylinder Bore Dia.	H.P.	2.501 / 2.500	3.001 / 3.000	3.251 / 3.250
	L.P.	4.503 / 4.502	5.251 / 5.250	6.001 / 6.000
Piston Skirt Dia.	H.P.	2.4985 / 2.4980	4.491 / 4.490	4.491 / 4.490
	L.P.	4.497 / 4.496		
Piston / Cylinder (at skirt)	H.P.	.0015 / .0030	.0015 / .0030	.0020 / .0035
	L.P.	.005 / .007	.004 / .006	.007 / .009
Crankshaft Dia. (at main bearing)		1.5015 / 1.5025	2.0015 / 2.0025	2.0015 / 2.0025
Housing Bore (at main bearing)		3.000 / 3.001	3.6718 / 3.6728	3.6718 / 3.6728
Crankshaft End Play		.0015 / .0030	.0015 / .0030	.0015 / .0030
Crankshaft Journal Size		1.7500 / 1.7505	2.2480 / 2.2485	2.2480 / 2.2485

		QRNG 370	QRNG 5120
Cylinder Bore Dia.	H.P.	3.251 / 3.250	3.251 / 3.250
	L.P.	6.001 / 6.000	6.001 / 6.000
Piston Skirt Dia.	H.P.	3.2480 / 3.2475	3.2480 / 3.2475
	L.P.	5.993 / 5.992	5.993 / 5.992
Piston / Cylinder (at skirt)	H.P.	.002 / .0035	.0020 / .0035
	L.P.	.007 / .009	.007 / .009
Crankshaft Dia. (at main bearing)		2.0015 / 2.0025	2.1265 / 2.1275
Housing Bore (at main bearing)		3.6718 / 3.6728	4.375 / 4.376
Crankshaft End Play		.0015 / .003	.0020 / .0035
Crankshaft Journal Size		2.2480 / 2.2485	2.2480 / 2.2485

Receiving Delivery

Immediately upon receipt of compressor equipment and prior to completely uncrating, the following steps should be taken:

- Step 1)** Inspect compressor equipment for damage that may have occurred during shipment. If any damage is found, demand an inspection from the carrier. Ask the carrier how to file a claim for shipping damages. (Refer to **SECTION 3, *Freight Damage*** for complete details.) **Shipping damage is not covered by Quincy Compressor warranty.**
- Step 2)** Insure that adequate lifting equipment is available for moving the compressor equipment.

CAUTION !

Improper lifting can result in component or system damage, or personal injury. Follow good shop practices and safety procedures when moving the unit.

- Step 3)** Read the compressor nameplate to verify the model and size ordered.
- Step 4)** Read the motor nameplate to be sure the motor is compatible with your electrical conditions (volts, phase, hertz).
- Step 5)** Read the pressure relief valve nameplate to be sure it does not exceed the working pressure shown on the compressor or any other component in the system.
- Step 6)** **Read and understand the safety precautions contained within this manual.** The successful and efficient operation of compressor equipment depends largely upon the amount of care taken to install and maintain the equipment. Quincy Compressor strongly recommends that any or all person(s) in charge of installing, maintaining, or servicing one of our compressors read and understand the entire contents of this manual in order to perform such duties safely and efficiently.

Freight Damage

It is extremely important that you examine every carton and crate as soon as you receive it. If there is any obvious damage to the shipping container, have the delivering carrier sign the freight bill, noting the apparent damage, and request a damage report.

If concealed damage is discovered at a later date, the carrier must be notified within 15 days of initial receipt of freight. Concealed shipping damage is not covered by Quincy Compressor Warranty. Contact the carrier as soon as possible, giving them an opportunity to inspect the shipment at the premises where the delivery was made. Do not move the damaged freight from the premises where the original delivery was made.

Retain all containers and packing for inspection by the carrier.

A claim form can be requested from the carrier: Standard Form for Presentation of Loss and Damage Claims (form # 3208). Your claim will need to be substantiated with the following documents:

- a.) form #3208
- b.) original bill of lading
- c.) original paid freight bill
- d.) original invoice or certified copy
- e.) other particulars obtainable in proof of loss or damage (photos, damage inspection, etc.)

The proper description and classification of our product in the National Motor Freight Classification 100-H, contained in item 118100, reads as follows: Compressors, air, or air ends: with or without air tanks, hose or nozzles, mounted or not mounted.”

We suggest that these instructions be circulated to your shipping and receiving personnel.

Location

Quincy natural gas compressors should be installed in an area that is clean, dry, well lighted, adequately ventilated and not more than 24 inches to a wall or another compressor. Inspection and maintenance checks are required daily, therefore, sufficient space needs to be provided around the compressor for safe and proper inspection, cleaning, and maintenance.

Allows ample circulation of air must be provided across the compressor cylinders, heads and cooler (if so equipped). Do not allow hot air from additional equipment to blow towards the compressor. If at all possible, the pulley drive system (i.e. motor pulley, compressor sheave, belts and guard) should be located next to a wall to minimize any danger created by the drive system while the compressor is operating.

The compressor should be operated in temperatures under 104°F. In cold climates, the compressor should be installed in a heated building.

CAUTION !

Do not operate this compressor in ambient temperatures lower than -15° F. A crankcase heater is recommended for a compressor that is to operate in temperatures under 32° F.

WARNING !

Under no circumstances should a compressor be used in an area that may be exposed to toxic or corrosive atmosphere. Do not store toxic or corrosive agents near the compressor.

Noise

Noise is a potential health hazard that must be considered. There are federal and local laws governing acceptable noise levels. Check with local officials for specifications.

Excessive noise can be effectively reduced through various methods. Total enclosures, intake silencers, baffle walls, relocating or isolating the compressor can reduce noise levels. Care must be taken when constructing total enclosures or baffle walls. If not properly constructed or positioned, they could contribute to unacceptable noise levels or overheating. Consult your local Quincy gas application distributor if assistance is required.

CAUTION !

Unusual noise or vibration indicates a problem. Do not operate the compressor until the source has been identified and corrected.

Electrical Supply Requirements

The electrical installation of this unit should be performed by a qualified electrician with knowledge of the National Electrical Code (NEC), OSHA. code and/or any local or state codes having precedence.

Before installation, the electrical supply should be checked for adequate wire size and transformer capacity. A suitable circuit breaker or fused disconnect switch should be provided. When a 3 phase motor is used to drive a compressor, any unreasonable voltage imbalance between the legs must be eliminated and any low voltage corrected to prevent excessive current draw. **Note: This unit must be grounded.**

The installation, electric motor, wiring, and all electrical controls must be in accordance with NFPA National Electric Code, National Electric Safety Code, state and local codes. Failure to abide by the national, state and local codes may result in physical harm and/or property damage.

DANGER !

High voltage may cause personal injury or death. Disconnect and lockout/tagout per OSHA. regulation 1910.147 all electrical power supplies before opening the electrical enclosure or servicing.

WARNING !

Never assume a compressor is safe to work on just because it is not operating. It could restart at any time. Follow all safety precautions outlined in SECTION 5, *Stopping For Maintenance*.

CAUTION !

NEMA electrical enclosures and components must be designed to operate in the area in which they are installed.

Mounting

Proper mounting of Quincy natural gas compressors is crucial to the safe operation and longevity of the equipment. The installation requires a flat and level concrete floor or pad. Satisfactory results can usually be obtained by mounting the compressor on vibration isolating pads available from your local Quincy gas application distributor. Refer to **Fig. 3-1, Isolator Installation for Unanchored or Anchored Receiver.**

State or local codes may mandate that the compressor be bolted to the floor. In this case the unit must be leveled and bolted making absolutely certain the feet are not stressed in any manner. ***Leave the flange nut loose & lock it with***

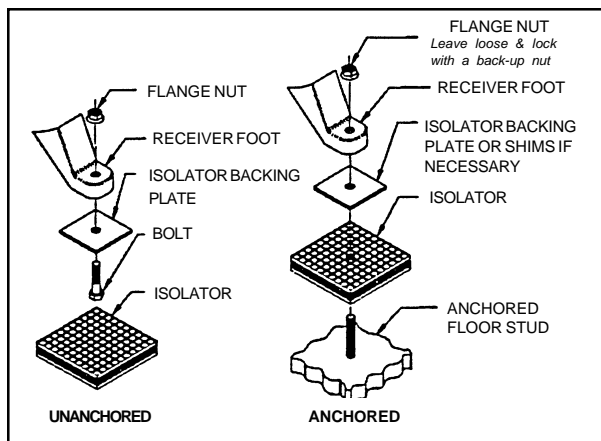

Fig. 3-1 Isolator Installation for Unanchored or Anchored Receiver

110365

a back-up nut! Uneven feet drawn tightly to the concrete pad will cause severe vibrations resulting in cracked welds or fatigue failure. The customer is responsible for providing a suitable foundation & isolator mounting where necessary.

System components

QRNG natural gas compressors are used for a wide range of applications, each with their own specific requirements for supportive and protective system components. For this reason Quincy Compressor includes minimal information regarding the vast array of available components.

Safety and efficiency are the primary concerns when selecting components for compressed natural gas systems. All components used on packaged QRNG compressors

must be designed to operate safely (at a minimum) in a Class 1, Division 2, Group D environment. Products of inferior quality can not only hinder performance of the unit, but could cause system failures that result in bodily harm or even death. Select only top quality components for your system. Call your local Quincy gas application distributor for quality parts and professional advice.

Drive Pulleys / Sheaves

Various pulley and sheave combinations are available to obtain the desired natural gas pressure and delivery rate of your compressor. Consideration must be given to these combinations to ensure that the motor is not overloaded by operating above or below the designed speed range.

Whatever combination is employed, the drive pulleys & compressor sheaves must be properly aligned and drive belt tension set to specifications (refer to **SECTION 5, Pulley / Sheave Alignment & Belt Tension**). Improper pulley/sheave alignment and belt tension can cause motor overloading, excessive vibration, and premature belt and/or bearing failure.

Excessive compressor RPM's (speed) could cause a pulley or sheave to shatter. In an instant, the pulley or sheave could separate into fragments capable of penetrating the belt guard and causing bodily harm or death. Do not operate the compressor above the recommended RPM listed in the parts book.

WARNING !

Guards

All mechanical action or motion is hazardous in varying degrees and needs to be guarded. Guards should be designed to achieve the required degree of protection and still allow full air flow from the compressor sheave across the unit. Guards shall be in compliance with OSHA safety and health standards 29 CFR 1910.219 in OSHA manual 2206 and any state or local codes.

Guards must be fastened in place before starting the compressor and never removed before cutting off and locking out the main power supply (refer to SECTION 5, Stopping for Maintenance).

WARNING !

DANGER !

Pressure Relief Valves

Pressure relief valves aid in preventing system failures by relieving system pressure when compressed natural gas reaches a determined level. They are available in various pressure settings to accommodate a range of applications. Pressure relief valves are preset by the manufacturer and under no circumstances should the setting be changed by anyone other than the manufacturer.

Pressure relief valves must be provided to protect compressed natural gas systems in accordance with ASME B19 safety standards. Failure to provide properly sized pressure relief valves may cause property damage, severe personal injury or even death.

Induction System

Scrubbers Dryers & Filters

On closed systems, the inlet piping must include the necessary filters and scrubbers to eliminate liquid or solid carry-over to the compressor. Additionally, protection from overpressurization must be provided.

It is the user's responsibility to provide adequate filtration. Warranty will be void if a failure is determined to be caused by inadequate filtration or overpressurization.

Pulsation Dampener

Remotely installed inlets can lead to vibrations in the inlet piping. These vibrations can be minimized by adding a pulsation dampener in between the remote inlet(s) and the compressor.

Compressed Natural Gas Discharge System

Discharge Piping

The discharge piping from the compressor should be made of steel pipe with cast iron fittings or welded steel joints. All of this piping should be of the same diameter as the compressor discharge connection. As with any piping, all parts of the discharge piping should fit so as not to create any stress between the piping and components.

WARNING !

Never join pipes or fittings by soldering. Always use welded or threaded steel pipes and cast iron fittings for compressor applications.

*Pre-starting Checklist***WARNING !**

Never assume a compressor is safe to work on just because it is not operating. It could restart at any time. Follow all safety precautions outlined in SECTION 5, *Stopping For Maintenance*.

WARNING !

Failure to perform the pre-starting checklist may result in mechanical failure, property damage, serious injury or even death.

Steps 1 through 12 should be performed prior to connecting the unit to a power source. If any condition of the checklist is not satisfied, make the necessary adjustments or corrections before starting the compressor.

- Step 1)** Remove all installation tools from the compressor and check for installation debris.
- Step 2)** **Check the lubricant level in the crankcase.** (Refer to SECTION 5, *Lubrication* for quantity and types of lubricant to be used.)
- Step 3)** Check motor pulley and compressor sheaves for alignment and tightness on shaft. (Refer to SECTION 5, *Pulley / Sheave Alignment & Belt Tension*.)
- Step 4)** Manually rotate the compressor sheave several rotations to be sure there are no mechanical interferences.
- Step 5)** Check inlet piping installation (Refer to SECTION 3, *Induction System*.)
- Step 6)** Check belt tension. (Refer to SECTION 5, *Pulley / Sheave Alignment & Belt Tension*.)
- Step 7)** Check all pressure connections for tightness.
- Step 8)** Make sure all pressure relief valves are correctly installed. (Refer to SECTION 3, *System Components*.)
- Step 9)** Be sure all guards are in place and securely mounted. (Refer to SECTION 3, *System Components*.)
- Step 10)** Check fuses, circuit breakers, and thermal overloads for proper size. (Refer to SECTION 3, *Electrical Supply Requirements*.)
- Step 11)** Open all manual shutoff valves at and beyond the compressor discharge.
- Step 12)** After all the above conditions have been satisfied, the unit can be connected to the proper power source.

Step 13) Jog the starter switch to check the rotational direction of the compressor. It must agree with the directional arrow embossed on the lubricant pump.

Step 14) Check for proper rotation of the cylinder cooling fan (fins inside sheave). The fan should blow cooling air across the cylinder.

Initial Starting & Operating

This instruction manual, as well as any instructions supplied by manufacturers of supporting equipment, should be read and understood prior to starting the compressor. If there are any questions regarding any part of the instructions, please call your point of sale distributor, local Quincy gas application distributor, or the Quincy Compressor factory.

With the pre-starting checklist completed and satisfied, start the compressor. Watch and listen for excessive vibration and strange noises. If either exist, stop the compressor. Refer to **SECTION 6, *Troubleshooting*** for help in determining the cause of such problems.

Observe compressor operation closely for the first hour of operation and then frequently for the next seven hours. After the first eight hours, monitor the compressor at least once every eight hours. If any abnormal conditions are witnessed, stop the compressor and correct the problem. After two days of operation check belt tension, lubricant level, and inspect the system for leaks.

Daily Starting Checklist

Do not proceed until the ***Pre-starting Checklist*** and ***Initial Starting & Operating*** sub-sections have been read and are thoroughly understood.

Step 1) Check lubricant level in crankcase.

Step 2) Drain liquid from the inlet scrubber, interstage scrubber and discharge system.

Step 3) Jog the starter button and check compressor rotation.

Step 4) Start compressor per factory instructions. (Refer to **SECTION 4, *Pre-Starting Checklist and Initial Starting & Operating.***)

Step 5) Check lubricant pressure while compressor is hot. Maintain 25 PSIG at rated speed and operating temperature.

Step 6) Check system pressure.

Step 7) Check cooling fan.

Step 8) Check all pressure relief valves for proper operation.

Step 9) Check control system for proper operation.

Stopping for Maintenance

It is vitally important to remember that internal pressure can exist inside a natural gas compressor whenever it is linked to a pressurized natural gas supply. Do not attempt to remove the dipstick, handhole plate, lubricant pump or filter, or any other parts of the compressor until the ***Stopping for Maintenance*** procedures have been read, understood and satisfied.

The following procedures should be followed when stopping the compressor for maintenance or service:

Step 1) Per OSHA regulation 1910.147: The Control of Hazardous Energy Source (Lockout/Tagout), disconnect and lockout the main power source. Display a sign in clear view at the main power switch stating that the compressor is being serviced.

WARNING !

Never assume a compressor is safe to work on just because it is not operating. It could restart at any time.

Step 2) Isolate the compressor from the compressed natural gas supply by closing a manual shutoff valve upstream and downstream from the compressor. Display a sign in clear view at the shutoff valve stating that the compressor is being serviced.

Step 3) Open a pressure relief valve within the pressurized system to allow the system to be completely de-pressurized. **NEVER** remove a plug to relieve the pressure!

Step 4) Open all manual drain valves within the area to be serviced.

Step 5) Wait for the unit to cool before starting to service. (Temperatures of 125°F can burn skin. Some surface temperatures exceed 350°F when the compressor is operating.)

Step 6) Allow ample time for the work area to be ventilated of all natural gas.

WARNING !

No smoking in any area near a natural gas compressor! Natural gas is highly explosive.

Maintenance Schedule

To assure maximum performance and service life of your compressor, a routine maintenance schedule should be developed. A sample schedule has been included here to help you to develop a maintenance schedule designed for your particular application. Time frames may need to be shortened in harsher environments.

At the back of this instruction manual you will find a **Maintenance Schedule Checklist**. Make copies of this checklist and retain the master to

make more copies as needed. On a copy of the checklist, enter dates and initials in the appropriate spaces. Keep the checklist and this instruction manual readily available near the compressor.

Maintenance Schedule Checklist Sample

Every 8 Hours (or Daily)

- Maintain lubricant level between high and low level marks on bayonet gauge. (Discoloration or a higher lubricant level reading may indicate the presence of condensed liquids.) If lubricant is contaminated, drain and replace.
- Drain drop legs and traps in natural gas distribution system.
- Give compressor an overall visual inspection and be sure safety guards are in place.
- Check for any unusual noise or vibration.
- Check lubricant pressure (*hot*). Maintain 25 PSIG at rated speed and operating temperature.
- Check for lubricant leaks.

Every 40 Hours (or Weekly)

- Manually operate the pressure relief valves to be certain they are working.
- Clean the cooling surfaces of the intercooler and compressor.
- Check the compressor for natural gas leaks.
- Check the compressed natural gas distribution system for leaks.
- Inspect lubricant for contamination & change if necessary.
- Change lubricant more often under humid or dirty conditions.

Every 160 Hours (or Monthly)

- Check belt tension
- Change lubricant & filter (more frequently in harsher environments).
- Torque pulley clamp screws or jamnut.

Every 500 Hours (or Every 3 Months)

- Inspect compressor valves for leakage and/or carbon build-up.

Lubrication

Quincy natural gas compressors are normally shipped with lubricant in the crankcase. Before starting this compressor, check the lubricant level in the crankcase. The lubricant should register between the high and low marks on the dipstick. **Replace the initial lubricant fill after 100 hours of operation or 1 month (whichever comes first). Use a non-detergent or synthetic lubricant only.**

Quin-Cip lubricant has proven under extensive testing to minimize friction and wear, limit lubricant carryover, and reduce carbon and varnish deposits. It will support the performance characteristics and life designed into all Quincy compressors and is highly recommended. Refer to the charts below to determine the correct amount of lubricant and viscosity to use for your model and application.

Approximate Crankcase Lubricant Capacities

Model	Less Lubricant Filter	With Lubricant Filter
240, 325	1-1/2 qts.	Add 10 oz.
270, 340, 350, 370	4-3/4 qts.	Add 10 oz.
4125, 5120	9-3/4 qts	Add 10 oz.

Lubricant Specifications

(Use a non-detergent or synthetic lubricant only.)

Ambient Temperature	SAE Viscosity	ISO Viscosity
0-32° F	SAE 20W	ISO 68
above 32°F	SAE 30	ISO 100

CAUTION !

The lubricant selected must have a pour point at least 15° F lower than the minimum expected ambient temperature.

A new or rebuilt reciprocating compressor will require up to 100 hours of operation at full discharge operating pressure to break-in the new piston rings. Until the rings are seated, the compressor will discharge higher than normal amounts of lubricant. In light of this fact, the lubricant level should be checked more frequently during the 100 hour break-in period.

Pulley / Sheave Alignment & Belt Tension

The correct drive pulley diameter must be selected to obtain proper pressure and natural gas delivery without overloading the motor, or operating the compressor above or below the designed speed range. It is equally important to properly align the compressor and drive pulley, and maintain the correct drive belt tension. Improper pulley alignment and belt tension are causes for motor overloading, excessive vibration, and premature belt and/or bearing failure.

Quincy Compressors's liability is limited to the basic compressor as supplied by Quincy Compressor, and is limited to defects in material and workmanship. Any modifications of system components related to the operation of the basic compressor such as (but not limited to) the suction and discharge connections and drive arrangements are the responsibility of the owner / operator.

Reversal of Compressor Rotation

QRNG natural gas compressors are originally designed to operate in a counterclockwise rotation. However, they can be modified to operate in reverse (clockwise) rotation. In order to do this, the lubricant pump must be reversed and a reverse rotation compressor pulley must be installed. Perform the following steps prior to operating the compressor in reverse rotation:

- Step 1)** Remove:
- the lubricant pressure gauge.
 - the lubricant filter (if so equipped).
 - 6 lubricant pump housing bolts.

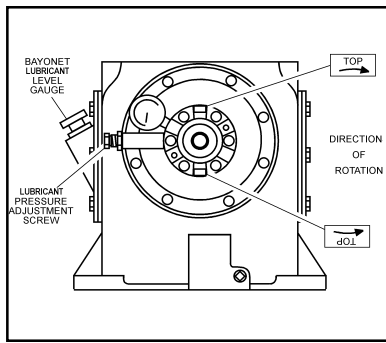

Fig. 5-1 Pix 1068
Compressor Directional Arrows

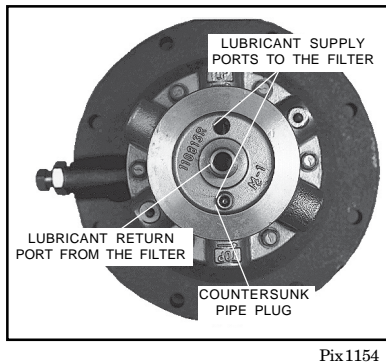

Fig. 5-2 Relocating Countersunk Pipe Plug Pix 1154

Step 2) Rotate the lubricant pump housing 1/2 turn (180°). (Note: The rotational arrow at the top of the pump housing should now reference the direction you wish the compressor to rotate. (See **Fig. 5-1, Compressor Directional Arrows**)

Step 3) Re-install the 6 housing bolts and torque them in a star or cross pattern to 6 ft.-lbs.

Step 4) Remove the countersunk pipe plug* from the lubricant pump housing and relocate it in the opposite (bottom) hole. (See **Fig. 5-2, Relocating Countersunk Pipe Plug**)

Failure to relocate this pipe plug will result in complete loss of lubricant flow throughout the compressor. Compressor seizure will result and warranty will be void. The countersunk pipe plug must always be relocated in the bottom port position.

Step 5) Install a new lubricant filter (if so equipped). Tighten the filter 1/2 turn after initial gasket contact.

Step 6) Re-assemble the control components in reverse order.

Step 7) Double check the directional arrows.

Step 8) Remove the original equipment compressor pulley and replace it with a reverse rotation pulley (available from your Quincy gas application distributor). Failure to swap pulleys will result in overheating and will void warranty. Be sure to torque the retaining screws to specifications.

Step 9) Start the compressor and adjust the lubricant pressure to 25 PSIG. Adjust the lubricant pressure by first loosening the locknut on the lubricant pressure adjustment screw (See **Fig. 5-1 Compressor Directional Arrows**). Turn the lubricant pressure adjustment screw clockwise to increase lubricant pressure; counterclockwise to decrease lubricant pressure. After adjustment is made, re-tighten the locknut.

Torquing Cylinder to Head Capscrews

Torque cylinder to head capscrews to specifications during assembly. Then, run the compressor for at least 30 minutes. Shut the unit off and follow precautions outlined in **SECTION 5, Stopping for Maintenance**. Retorque the head capscrews to same specifications while the unit is still hot.

Trouble	Probable Cause
Low discharge pressure & natural gas delivery	<ul style="list-style-type: none"> •Restricted inlet •Defective compressor valves •Leaks in the plant natural gas system at fittings, connections, etc. •Pressure switch defective or set wrong •Drive belt slipping •Incorrect speed •Worn piston rings or loose piston •Leaking head gasket •Low lubricant pressure •Drain valve open •Defective pressure gauge •Excessive running clearances (<i>refer to SECTION 2, Specifications</i>) •Pressure relief valve leaking •Clogged intercooler •Loose compressor valves or leaking at valve gaskets •Compressor incorrectly sized for the altitude at which it is operating •Piston rings not seated; allow 100 hours at full pressure
Low natural gas delivery	<ul style="list-style-type: none"> •Low inlet pressure •Excessive discharge pressure
Water in the crankcase (lubricant appears milky)	<ul style="list-style-type: none"> •Compressor does not run long enough to get hot and vaporize the liquids squeezed out of the natural gas during compression •Incorrect or inferior grade of lubricant •System pressure leaking back through discharge valve •Faulty inlet scrubber
Rusty valves and/or cylinders	<ul style="list-style-type: none"> •Compressor operated too infrequently •Compressor does not run long enough to get hot and vaporize the liquids squeezed out of the natural gas during compression (<i>compressor may be too large for application</i>) •Compressor not properly prepared for storage •Discharge line from compressor head is pointed upward allowing condensation to drain back at shutdown •Faulty inlet scrubber
Excessive vibration	<ul style="list-style-type: none"> •Incorrect speed •Compressor valves not functioning properly •Loose pulley/sheave •Motor or engine out of balance •Compressor, motor or engine not secured tightly, or tightened into a bind •Foundation or frame inadequate

Trouble

Probable Cause

Excessive Vibration (cont.)

- Piping inadequately supported or tightened into a bind
- Excessive discharge pressure
- Compressor feet may need to be leveled with shims

Excessive drive belt wear

- Pulley/sheave out of alignment
- Belt too loose or too tight
- Belt slipping
- Pulley/sheave wobbling
- Pulley/sheave groove damaged or rough
- Incorrect belts

Low lubricant pressure

- Lubricant pump direction reversed
- Lubricant sump strainer plugged
- Excessive leakage at crankshaft seals
- Low lubricant level
- Lubricant pump incorrectly assembled to the bearing carrier (“o”ring not properly located between lubricant pump body & bearing carrier)
- Lubricant pressure adjusting screw not set properly
- Defective lubricant pressure gauge
- Plugged lubricant filter

Compressor overheats

- Clogged intake system
- Defective compressor valves
- Pressure setting too high
- Clogged intercooler, internally or externally
- Inadequate ventilation, or recirculation of hot air
- Pulley/sheave rotation wrong
- Incorrect speed
- Running clearances insufficient (*piston to cylinder wall or running gear*)
- Lubrication inadequate
- Compressor incorrectly sized

High discharge temperature

- Compressor valve assemblies defective
- Discharge pressure too high
- Inadequate ventilation or hot air recirculating
- Cooling surfaces of compressor or intercooler excessively dirty
- Internal surface of heat exchanger fouled
- Ambient temperature too high
- Scored or excessively worn cylinder walls

Compressor knocks

- Head clearance insufficient
- Piston loose in cylinder bore, cylinder bore worn, piston or piston rings worn
- Worn rods or main bearing
- Wrong pressure setting, discharge pressure excessive
- Crankcase lubrication inadequate
- Loose pulley/sheave
- Compressor valve assemblies loose

Trouble

Probable Cause

Excessive lubricant consumption

- Worn piston rings
- Restricted intake system
- Compressor running too hot
- Breather valve not functioning properly
- Lubricant level in crankcase too high
- Lubricant viscosity wrong for the application
- Connecting rod out of alignment, bent or twisted
- Leaking lubricant seal
- Piston rings not seated (*allow 100 hours for seating*)
- Wrong lubricant (*may be a detergent lubricant with a tendency to foam*)
- Inferior grade of lubricant

Excessive current draw

(To determine maximum amperage allowed, multiply the FLA on the motor nameplate by the service factor.)

CAUTION!

Motor surface temperature normally exceeds 170° F.

- Low voltage (*must be within 10% of nameplate voltage*)
- Loose electrical connection
- Wire size too small
- Incorrect lubricant
- Discharge pressure too high
- Intercooler plugging
- Bearings tight or seizing
- No crankshaft endplay
- Motor sized incorrectly
- Motor defective
- Drive belts too tight

Failure to start

- Power not on
- Blown circuit fuse
- Thermal overload fuses tripped
- Low voltage
- Faulty start switch
- Power failure
- Pressure switch incorrectly adjusted or faulty
- Loose or broken wire
- Motor defective
- Compressor seized

Motor stalls

- Motor overloaded (*refer to Excessive current draw*)

QUINCY COMPRESSOR

STANDARD TERMS AND CONDITIONS

LEGAL EFFECT: Except as expressly otherwise agreed to in writing by an authorized representative of Seller, the following terms and conditions shall apply to and form a part of this order and any additional and/or different terms of Buyer's purchase order or other form of acceptance are rejected in advance and shall not become a part of this order.

The rights of Buyer hereunder shall be neither assignable nor transferable except with the written consent of Seller.

This order may not be canceled or altered except with the written consent of Seller and upon terms which will indemnify Seller against all loss occasioned thereby. All additional costs incurred by Seller due to changes in design or specifications, modification of this order or revision of product must be paid for by Buyer.

In addition to the rights and remedies conferred upon Seller by this order, Seller shall have all rights and remedies conferred at law and in equity and shall not be required to proceed with the performance of this order if Buyer is in default in the performance of such order or of any other contract or order with seller.

TERMS OF PAYMENT: Unless otherwise specified in the order acknowledgment, the terms of payment shall be 1% 15, net forty-five (45) days after shipment. These terms shall apply to partial as well as complete shipments. If any proceeding be initiated by or against Buyer under any bankruptcy or insolvency law, or in the judgment of Seller the financial condition of Buyer, at the time the equipment is ready for shipment, does not justify the terms of payment specified, Seller reserves the right to require full payment in cash prior to making shipment. If such payment is not received within fifteen (15) days after notification of readiness for shipment, Seller may cancel the order as to any unshipped item and require payment of its reasonable cancellation charges.

If Buyer delays shipment, payments based on date of shipment shall become due as of the date when ready for shipment. If Buyer delays completion of manufacture, Seller may elect to require payment according to percentage of completion. Equipment held for Buyer shall be at Buyer's risk and storage charges may be applied at the discretion of Seller.

Accounts past due shall bear interest at the highest rate lawful to contract for but if there is no limit set by law, such interest shall be eighteen percent (18%). Buyer shall pay all cost and expenses, including reasonable attorney's fees, incurred in collecting the same, and no claim, except claims within Seller's warranty of material or workmanship, as stated below, will be recognized unless delivered in writing to Seller within thirty (30) days after date of shipment.

TAXES: All prices exclude present and future sales, use, occupation, license, excise, and other taxes in respect of manufacture, sales or delivery, all of which shall be paid by Buyer unless included in the purchase price at the proper rate or a proper exemption certificate is furnished.

ACCEPTANCE: All offers to purchase, quotations and contracts of sales are subject to final acceptance by an authorized representative at Seller's plant.

DELIVERY: Except as otherwise specified in this quotation, delivery will be F. O. B. point of shipment. In the absence of exact shipping instruction, Seller will use its discretion regarding best means of insured shipment. No liability will be accepted by Seller for so doing. All transportation charges are at Buyer's expense. Time of delivery is an estimate only and is based upon the receipt of all information and necessary approvals. The shipping schedule shall not be construed to limit seller in making commitments for materials or in fabricating articles under this order in accordance with Seller's normal and reasonable production schedules.

Seller shall in no event be liable for delays caused by fires, acts of God, strikes, labor difficulties, acts of governmental or military authorities, delays in transportation or procuring materials, or causes of any kind beyond Seller's control. No provision for liquidated damages for any cause shall apply under this order. Buyer shall accept delivery within thirty (30) days after receipt of notification of readiness for shipment. Claims for shortages will be deemed to have been waived if not made in writing with ten (10) days after the receipt of the material in respect of which any such shortage is claimed. Seller is not responsible for loss or damage in transit after having received "In Good Order" receipt from the carrier. All claims for loss or damage in transit should be made to the carrier.

TITLE & LIEN RIGHTS: The equipment shall remain personal property, regardless of how affixed to any realty or structure. Until the price (including any notes given therefore) of the equipment has been fully paid in cash, Seller shall, in the event of Buyer's default, have the right to repossess such equipment.

PATENT INFRINGEMENT: If properly notified and given an opportunity to do so with friendly assistance, Seller will defend Buyer and the ultimate user of the equipment from any actual or alleged infringement of any published United States patent by the equipment or any part thereof furnished pursuant hereto (other than parts of special design, construction, or manufacture specified by and originating with Buyer), and will pay all damages and costs awarded by competent court in any suit thus defended or of which it may have had notice and opportunity to defend as aforesaid.

STANDARD WARRANTY: Seller warrants that products of its own manufacture will be free from defects in workmanship and materials under normal use and service for the period specified in the product instruction manual. Warranty for service parts will be Ninety (90) days from date of factory shipment. Electric Motors, gasoline and diesel engines, electrical apparatus and all other accessories, components and parts not manufactured by Seller are warranted only to the extent of the original manufacturer's warranty.

Notice of the alleged defect must be given to the Seller, in writing with all identifying details including serial number, type of equipment and date of purchase within thirty (30) days of the discovery of the same during the warranty period.

Seller's sole obligation on this warranty shall be, at its option, to repair or replace or refund the purchase price of any product or part thereof which proves to be defective. If requested by Seller, such product or part thereof must be promptly returned to seller, freight prepaid, for inspection.

Seller warrants repaired or replaced parts of its own manufacture against defects in materials and workmanship under normal use and service for ninety (90) days or for the remainder of the warranty on the product being repaired.

This warranty shall not apply and Seller shall not be responsible or liable for:

- (a) Consequential, collateral or special losses or damages;
- (b) Equipment conditions caused by fair wear and tear, abnormal conditions of use, accident, neglect or misuse of equipment, improper storage or damage resulting during shipping;
- (c) Deviation from operating instructions, specifications or other special terms of sale;
- (d) Labor charges, loss or damage resulting from improper operation, maintenance or repairs made by person(s) other than Seller or Seller's authorized service station.

In no event shall Seller be liable for any claims whether arising from breach of contract or warranty or claims of negligence or negligent manufacture in excess of the purchase price.

THIS WARRANTY IS THE SOLE WARRANTY OF SELLERS AND ANY OTHER WARRANTIES, WHETHER EXPRESS OR IMPLIED IN LAW OR IMPLIED IN FACT, INCLUDING ANY WARRANTIES OF MERCHANTABILITY AND FITNESS FOR PARTICULAR USE ARE HEREBY SPECIFICALLY EXCLUDED.

LIABILITY LIMITATIONS: Under no circumstances shall the Seller have any liability for liquidated damages or for collateral, consequential or special damages or for loss of profits, or for actual losses or for loss of production or progress of construction, whether resulting from delays in delivery or performance, breach of warranty, negligent manufacture or otherwise.

ENVIRONMENTAL AND OSHA REQUIREMENTS: At the time of shipment of the equipment from the factory, Quincy Compressor / Ortman Fluid Power will comply with the various Federal, State and local laws and regulations concerning occupational health and safety and pollution. However, in the installation and operation of the equipment and other matters over which the seller has no control, the Seller assumes no responsibility for compliance with those laws and regulations, whether by the way of indemnity, warranty or otherwise.

June 30, 2003

MAINTENANCE SCHEDULE CHECKLIST

Use this form to develop a routine maintenance schedule and record of performed maintenance. In the numbered columns enter the initials of the person who performed the maintenance and the date. Enter additional maintenance procedures in the spaces provided in the left hand column as needed per your application.

Equipment operating under humid or dirty conditions may require shorter intervals between scheduled maintenance.

The instruction manual provided with Quincy Compressor products, as well as any instructions supplied by manufacturers of supporting equipment, should be read and understood prior to performing maintenance.

NOTE: Make your entries on a copy of this form. Retain this original form to make more copies in the future.

Suggested Weekly (40 hrs.) Intervals

Maintenance Procedures	1	2	3	4	5	6	7	8	9	10	11	12
•manually test pressure relief valves												
•												
•clean surfaces of intercooler												
•												
•check distribution system for leaks												
•												
•check for contaminated lubricant *												
•												
•check for compressor/vacuum leaks												
•												
•												

Suggested Monthly (160 hrs.) Intervals

Maintenance Procedures	1	2	3
•check belt tension (if applicable)			
•			
•torque sheave fasteners (if applicable)			
•			
•change lubricant (& filter if applicable)*			
•			

*QRD Series excluded



an EnPro Industries company

Reciprocating / Systems: 217.222.7700
Air Master 217.277.0270
E-mail: info@quincycompressor.com
Website: quincycompressor.com
quincyairmaster.com



© 2006 Quincy Compressor, an EnPro Industries company
All Rights Reserved. Litho in U.S.A.